

INTERACTIVE PEN DISPLAY

# DTI-520UB

User's Guide

유저 가이드

User's Guide

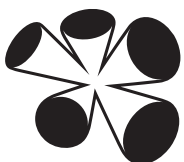

유저 가이드

















wacom®

# So that the DTI-520UB may be Used Safely...

The following symbols appear throughout this user guide in order to ensure safe use of the DTI-520UB (hereafter referred to as “DTI-520UB,” “the product” or “this product”). Please read these items carefully and always heed the Warning and Caution items when using your DTI-520UB.

	<b>Warning</b>	This symbol indicates an item that, if ignored when handling the product, could lead to the loss of life or serious injury.
	<b>Caution</b>	This symbol indicates an item that, if ignored when handling the product, could lead to injury or damage to personal property.

- Meanings of Symbols:**
-  Indicates that it is important to be careful when taking the action or actions noted.
  -  Indicates that the action or actions noted are to be avoided.
  -  Indicates it is important to take the action or actions noted.

 <b>Warning</b>	
<p>■ <b>Do not use the product in a facility control system that requires an extremely high level of reliability.</b></p> <p>This product may cause other electronic devices to malfunction, or other devices may cause this product to malfunction. </p>	<p>■ <b>Regarding the power plug and power adapter.</b></p> <ul style="list-style-type: none"> <li>- Please remove dust from the power plug regularly. The addition of moisture, etc. to accumulated dust may lead to fire. </li> <li>- Please do not use any power adapters other than those included with the product. Ignoring this warning may result in fire or product failure. </li> <li>- Please do not damage or forcibly bend or bundle the power adapter cord. Also, please do not place heavy objects on it or expose it to excessive heat. Ignoring this warning may result in fire, electric shock or product failure. </li> <li>- In the unlikely case that the power adapter should produce smoke or a strange odor, please disconnect it from the wall outlet and return it to either the store where you purchased it or to the Wacom Customer Support Center for repair service. </li> <li>- Please do not connect or disconnect the power adapter with wet hands. Ignoring this warning may result in electric shock or malfunction. </li> <li>- Please do not open or otherwise change the power adapter. Ignoring this warning may result in fire or electric shock. </li> </ul>
<p>■ <b>Turn this product off in places where the use of electronic equipment is prohibited.</b></p> <p>In airports, hospital intensive care units and other such places where the use of electronic equipment is prohibited, this product may adversely affect the operation of other electrical devices. In order to prevent this, when in such locations, always disconnect the product's USB connector from your computer and turn off the switch. </p>	
<p>■ <b>Do not open the back cover.</b></p> <p>Inside this product there are several high-voltage parts. Persons other than professional service personnel should never open the back cover of this product. Unauthorized opening of the back cover may lead to fire or electric shock.  </p>	
<p>■ <b>When this product ceases to operate normally due to being dropped or a similar cause, remove the power source cable from the electrical outlet.</b></p> <p>Leaving the power cable connected may result in fire or electric shock. </p>	

# ⚠ Caution

## ■ Do not use organic solvents to clean this product.

When cleaning the product, never use such organic solvents as alcohol. Such solvents may cause discoloration and deterioration in quality.



## ■ Do not let the product get wet.

Please do not place containers such as cups and vases containing water near the product. Coming in contact with water or other liquids may cause product failure.



## ■ When cleaning this product, always disconnect the USB connector.

When cleaning the product, always disconnect the USB connector from the USB port of the computer. Failure to do so may result in electric shock.



## ■ While this product is in use, avoid placing any metal objects on it.

Do not place any metal objects on the product while you are using it. This may result in malfunction or product failure.



## ■ Do not touch any liquids that may be leaking from this product.

The liquid contained in the product is an irritant. In the unlikely case that such liquid should leak, never touch it with bare hands. In case of contact with skin, mouth or eyes, rinse immediately with running water and continue rinsing for 15 minutes or longer. Also consult a physician.



## ■ Do not use excessive force with the cable.

Please do not step on, or place heavy objects on any of the product's cables. Also, do not apply excessive force to the base of the cable or repeatedly bend and stretch it, as this may cause it to break or malfunction.



## ■ Do not place the product on unstable surfaces.

Do not place the product where it is likely to totter, lean or be exposed to strong vibrations. Doing so may lead to the product falling, resulting in injury and/or product failure.



## ■ Do not place heavy objects on the product.

Do not put excessive weight, or place heavy objects on the product. These actions may cause product failure.



## ■ When connecting the power plug

When plugging the power adapter into an electrical outlet, also connect a grounded wire.



## ■ When not using this product for a long period of time

For safety reasons, when you will not be using the product for a considerable length of time, disconnect the power adapter from the electrical outlet.



## ■ Do not use this product in a dusty environment.

Dust can cause damage to the product.



## ■ Do not block the ventilation holes on the backside of the product.

Blocking these holes may cause internal overheating and subsequent damage.



## ■ Do not pick up the product by its stand.

If excessive force is used in handling the stand, its open and close function may become damaged. When picking up the product, always pick it up by the body.



## ■ Regarding the Grip Pen

-Do not strike hard objects with the metal Grip Pen. Doing so may cause damage to the product.

-Be careful to not allow small children to put either the pen or the spare nib into their mouths. There is the danger that the nib or side switch may be accidentally swallowed or that the grip pen may be damaged.



## Caution

### ■ Do not place the product in either very hot or very cold places.

Do not place the product in very hot (35 degrees centigrade or more) or very cold (5 degrees centigrade or less) locations. Also, avoid placing it in locations with severe temperature fluctuations as this may adversely affect the product and cause product failure.



### ■ Do not disassemble the product.

Do not disassemble or modify the product, as these actions may lead to fire, excessive generation of heat, electrical shock or injury. The guarantee on the product will become null and void if the product is ever disassembled.

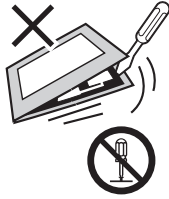

### ■ Do not connect or disconnect any cable while the product or your computer is on.

Do not connect or disconnect any cable (including the USB cable) or the power adapter while your computer or this product is turned on. This may cause damage to the product or to your computer.



## **Please take the following precautions to protect the health of your eyes.**

- When using the product, make sure that the room is sufficiently illuminated and be careful not to get your face too close to the screen.
- Take regular breaks when using the product over an extended period of time.

## **Warranty Exclusions**

- Wacom will not bear any responsibility for damage caused by fire, earthquake, accidents caused by third persons, intentional or accidental abuse by the customer or any other damage caused by abnormal use of the product.
- Wacom will not bear any responsibility for contingent damages (such as loss of business profits, suspension of operations, alterations to and disappearance of data, etc.) caused by use of, or inability to use, this product.
- Wacom will not bear any responsibility for damage resulting from the use of this product in a fashion other than as explained in this user guide.
- Wacom will not bear any responsibility for damage resulting from malfunctions caused by using this product in conjunction with adaptation equipment or other company's software.

## **Regarding warranty of the product**

Wacom warrants the product, to the original consumer purchaser, except software, to be free from defects in materials and workmanship under normal use and service as long as the product remains in production, but not less than one (1) year, from the date of original retail purchase, as evidenced by a copy of the receipt or a registration card that has been returned to Wacom within 30 days of purchase.

## **Regarding Trademarks**

- Wacom are registered trademarks of WACOM Company, Limited.
- Windows is a trademark of Microsoft Corporation, registered in the United States and other countries.
- Macintosh is a trademark of Apple Computer, Inc., registered in the United States.
- Other product names and related items are the trademarks or registered trademarks of each concerned company.

## **Precautions**

- 1 Wacom Company, Ltd. holds the copyright to the auxiliary tablet.
- 2 The unauthorized duplication or reproduction in whole or in part of the tablet driver or this user guide is expressly prohibited.
- 3 Wacom reserves the right to change the configurations or specifications of the tablet driver or the product, as well as the contents of this user guide, without prior notice.

## **Regarding this User Guide**

This user guide contains instructions regarding the set up, installation, functions and methods of use of this product. The product consists of the LCD monitor and the tablet, which will act as two distinct pieces of equipment to be used in conjunction with your computer. First, you will set up the display device and then you will install the tablet driver in your computer. You will then be able to use this product as a built-in display tablet.

Analog RGB compatible video output is necessary for the screen display of this product. For information regarding how to use video cards, refer to the instruction manual accompanying the video card.

## **Please be aware of the following regarding the LCD display.**

Depending on what is being displayed, bright or dark green, red and blue dots may show up on a very small portion of the LCD display screen. These do not indicate product failure or a lack of quality.

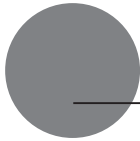

# Table of Contents

---

<b>So that the DTI-520UB may be Used Safely...</b>	<b>1</b>
<b>Table of Contents</b>	<b>5</b>
<b>Component Functions</b>	<b>6</b>
Opening the Stand.....	7
Using the Penholder.....	7
Installing DTI-520UB on a Mount Arm.....	8
<b>Accessory Check</b>	<b>9</b>
<b>Connecting DTI-520UB</b>	<b>10</b>
<b>Installing DTI-520UB Driver</b>	<b>12</b>
Windows Setup.....	12
Macintosh Setup.....	13
Uninstalling the Tablet Driver.....	13
<b>The DTI-520UB Display</b>	<b>14</b>
Switching Display Images.....	14
The Auto-Adjust Function.....	14
The DTI-520UB Power Saving Function.....	14
Protrusion of the Picture from the LCD Panel and the Blurring of Characters... ..	15
Button Functions.....	16
Adjusting the Brightness and Contrast of the Display.....	16
<b>Pen</b>	<b>19</b>
Basic Operations of the Pen.....	19
How to use the Tablet Button.....	20
<b>Using the Control Panel</b>	<b>21</b>
Displaying the Control Panel.....	21
Control Panel Basics.....	21
Synchronizing the Positions of the Pen Tip and Pointer.....	22
<b>Setup Procedures for when Multiple Interactive Pen Tablets are Connected</b>	<b>23</b>
<b>Supplementary Information</b>	<b>24</b>
Removing Stains.....	24
Replacing the Pen Nib.....	24
<b>Troubleshooting</b>	<b>25</b>
TDisplay Troubleshooting.....	25
The Pen and Side Switch do not Operate Correctly (For Both Windows and Macintosh).....	26
General Troubleshooting.....	27
Troubleshooting for Windows.....	27
Troubleshooting for Macintosh.....	27
<b>Specification</b>	<b>28</b>
<b>Warranty</b>	<b>29</b>
<b>Obtaining Technical Support</b>	<b>30</b>

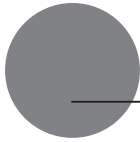

# Component Functions

## Front

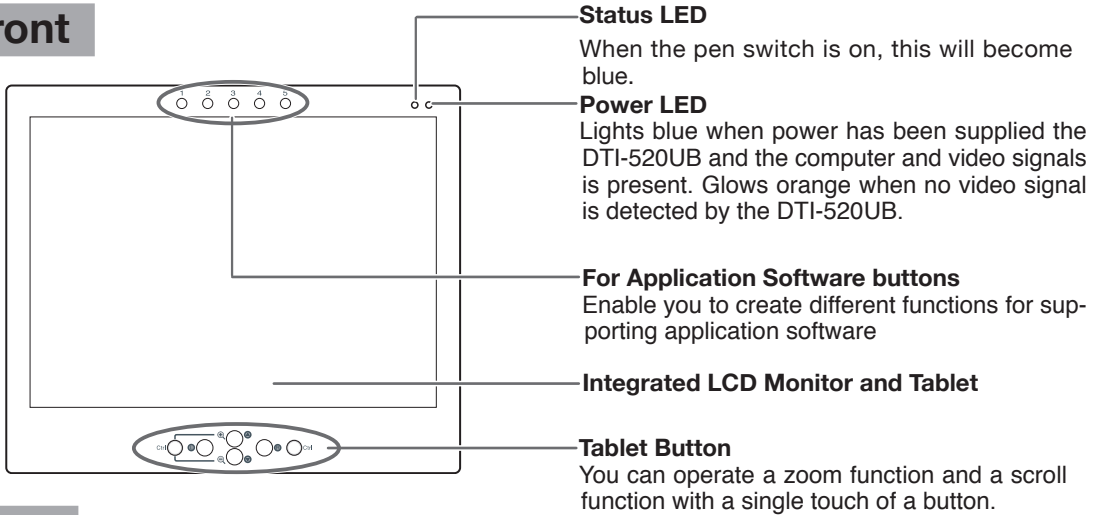

## Top

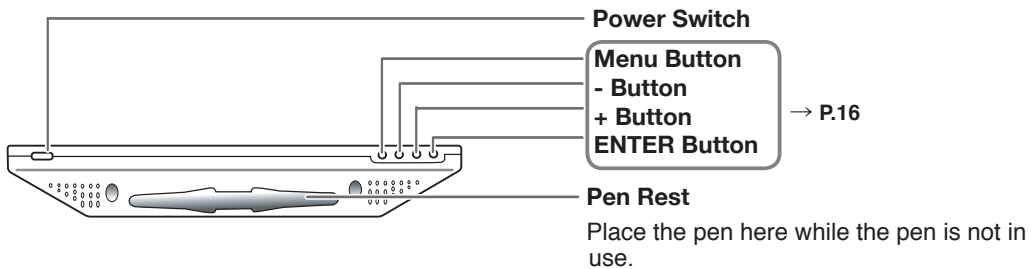

## Back

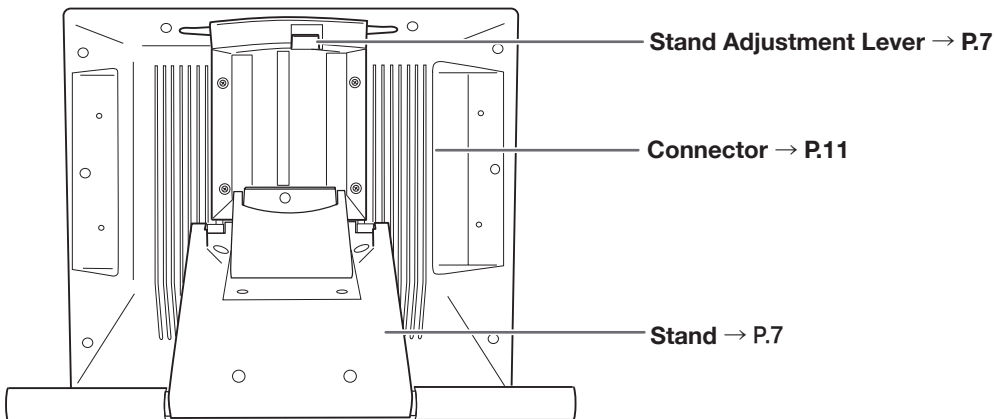

## Opening the Stand

**1** Pull up on the stand adjustment lever.

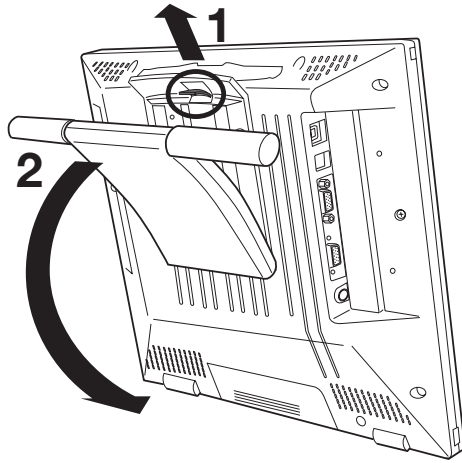

**2** Let the stand down.

## Using the Penholder

Pull the penholder towards you as shown in the illustration below.

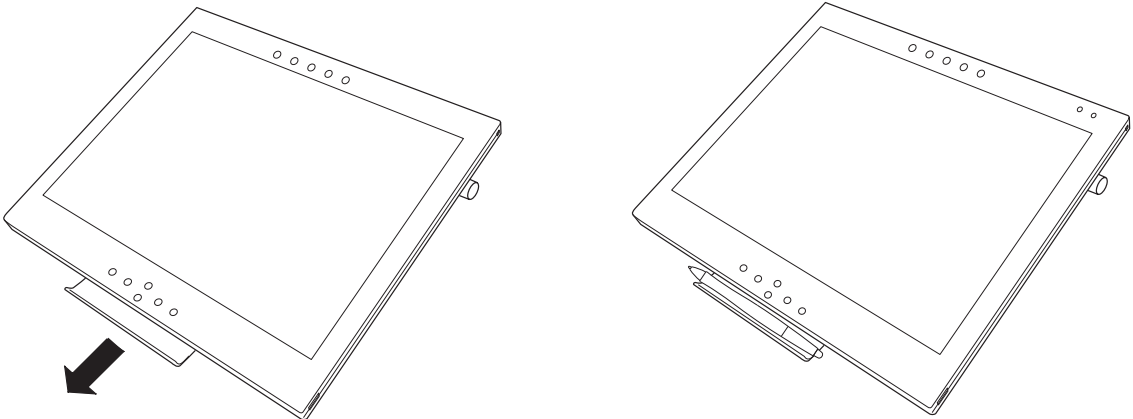

### **⚠ Caution**

Always close the stand and, as shown in the above illustration, lay the tablet on its side before pulling the penholder out.

## Installing DTI-520UB on a Mount Arm

This product conforms to the Video Electronics Standard Association's (VESA) Flat Panel Monitor Physical Mounting Interface Standard (FPMPMI).

This product can be removed from the stand and mounted on such apparatuses as a VESA-standard mount arm. In order to do this, M4/0.7 mm screws, which are not included with the product, are needed. Use screws that will, at the time of installation, penetrate the surface of the product by no more than 15 mm. Use of longer screws may result in damage to internal parts of the product.

- 1** Make sure that both your computer and the product are turned off and that all cables are disconnected.
- 2** Place the display unit face down on a flat surface. To prevent harm to the front of the unit, first spread a cloth or other similar material on the flat surface.
- 3** Remove the four screws that hold the stand to the unit.
- 4** Using four M4/0.7mm screws, securely mount the arm or similar apparatus to the back of the unit.

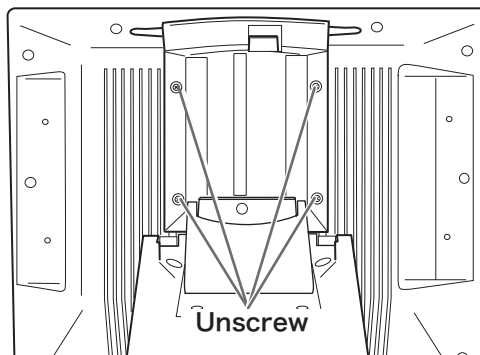

### **Caution**

When installing the unit on a mount arm or other stand, always follow the directions in the instruction booklet for the mount arm or stand, as well as the instructions contained in this document. Incorrect installation may result in the product coming loose and falling and possibly causing product failure.

- 5** Connect the cables and save the screws that you removed in step 3.

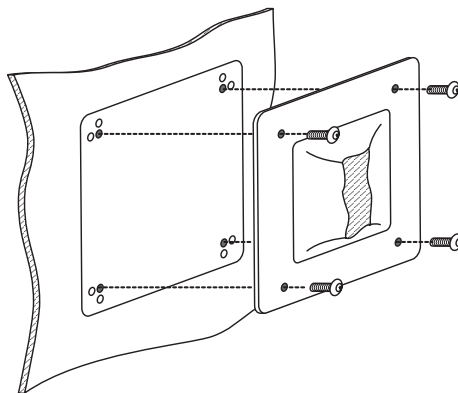

# Accessory Check

## ● Pen

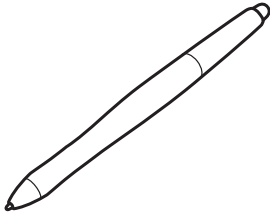

## ● Power Adapter

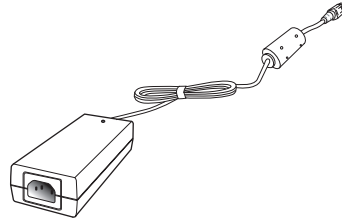

## ● User Guide (This booklet)

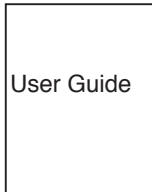

## ● Power Cable

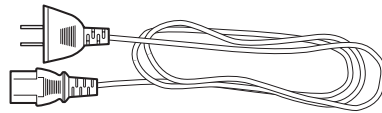

## ● Application Install Guide



## ● Serial Cable

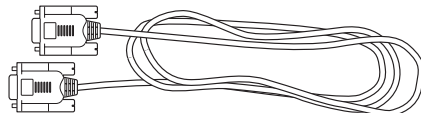

## ● Tablet Driver CD - ROM / Application CD - ROM

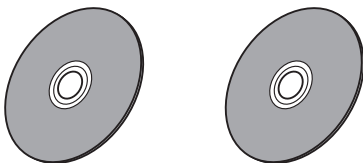

## ● USB Cable

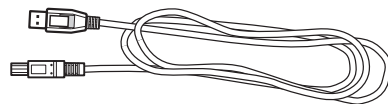

**Important :** Do not throw the box away; it is useful for the storage and transport of the product.

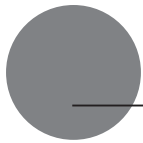

# Connecting DTI-520UB

---

- 1** Turn off both your computer and the product.
- 2** Connect the Analog-RGB connector to your computer's display port.
- 3** Connect the power adapter to the power cable and connect the DC power connector to the DC power input terminal. Next, plug the power cable into your electrical outlet.  
Be sure to also connect a ground wire.

**4** Turn on the product's power switch.  
The power indicator lamp will light up orange.

**5** Turn on your computer.

**6** While looking at the LCD screen, configure the color resolution and size settings.

**Caution:-** Do not modify the refresh rate. Setting the rate to a value that exceeds the DTI-520UB refresh rate may result in loss of picture.

- The color palette settings and corresponding number of colors displayed are as follows:  
High Color (16 bit) → 65,536 colors / True Color (24 bit) → Roughly 1,619 colors

\*The number of colors is limited by the efficiency of your computer and video card. For details, refer to the user's manual provided by the manufacturers.

**7** Turn off your computer and the product.

**8** Connect a USB connector of the product to a USB port of your computer using a USB cable.

**9** Turn on your computer and the product.

**10** Install the DTI-520UB driver (Please refer to "Installing DTI-520UB Driver" on page 12).

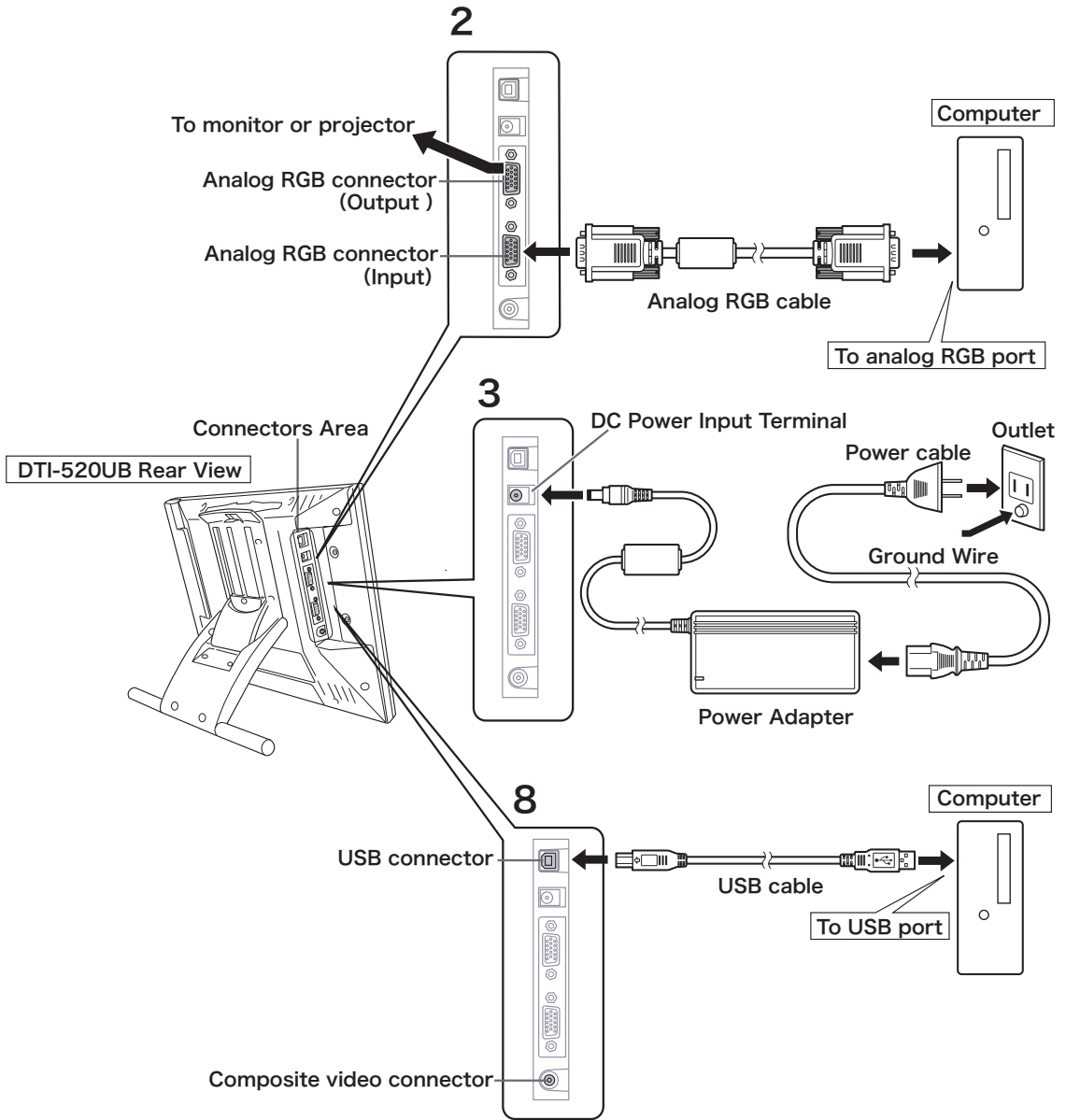

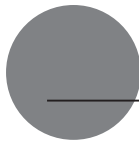

# Installing DTI-520UB Driver

## Windows Setup

Before installation, connect the DTI-520UB USB cable to your computer and turn the unit on.

### Installing the Tablet Driver

- 1** Insert the tablet driver CD into the CD-ROM drive. The install menu should automatically display. If the menu does not display, double-click on the INSTALL icon (located on the CD).
- 2** The install menu will appear. When you click on INSTALL TABLET, the LICENSE AGREEMENT dialog will appear.
- 3** Click Accept.
- 4** When the installation finishes, click OK.
- 5** Next, install the button driver.
- 6** Click NEXT in the WELCOME TO WACOM BUTTON DRIVER VER.x.xx SETUP dialog.
- 7** The LICENSE AGREEMENT dialog will appear. Click Next.
- 8** Follow the prompts to install the driver software.
- 9** The INSTALLWIZARD COMPLETE dialog will appear. Click FINISH.
- 10** Return to the install menu. Click FINISH.
- 11** See "How to use the Tablet Buttons" section (P.16) for more info about tablet buttons.

**Hint:** The latest information about the DTI-520UB driver is described in the technical note. Please read it certainly after the driver is installed.

## Macintosh Setup

- 1 Connect the USB cable to your computer, turn on the product and start up your Macintosh.
- 2 Close any open applications and temporarily turn off any virus-monitoring programs.
- 3 Insert the Tablet Driver CD-ROM into your computer's CD-ROM drive. The install menu will appear. If it doesn't appear, open the CD-ROM and double-click on Install or Install.app.  
**Hint:** \*After installing OS X, input your password.
- 4 Click on Install Wacom Tablet and installation will begin. Thereafter, follow the screen instructions and continue the installation process. If during processing, the identity confirmation dialog box displays, input your password \*.  
**Hint:** \*After installing OS X, input your password.
- 5 After the tablet driver installation is complete, restart Macintosh.  
**Caution:** Macintosh OS x 10.2 and newer versions include as a standard feature the Inkwell function. If this function is on, the yellow Inkwell memo pad will appear after installation of the Tablet Driver. To disable this function, click on Ink from the Control Panel, click on Settings and remove the checkmark from Allow Me to Write Anywhere.

## Uninstalling the Tablet Driver

### Windows

- 1 Click on the Windows Start button and open the control panel. Double click the Add and Delete Program (Application) icon.
- 2 Select Pen Tablet from the list and click the Modify (Add) and Delete button. Follow the instructions in the dialog box to initiate uninstall.  
If Windows is restarted, it is deleted.

### Macintosh

- 1 Open the Applications folder and then open the Tablet folder.
- 2 Start up Remove Tablet and follow the instructions to initiate uninstall.

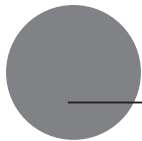

# The DTI-520UB Display

## Switching Display Images

Either an image input from the RGB – RGB cable (see P. 11) or an image input from the composite video cable will be displayed on the DTI-520UB. Either of these images can be replaced by using the following method:

- Switch at the INPUT CONVERSION screen, which can be accessed from the menu screen. ( → P.18)
- Click on the ENTER button.( → P.16)

**Hint:** If both the RGB – RGB cable and the composite video cable are connected, and then you turn the unit on, the image input from the RGB – RGB cable takes priority and is displayed.

## The Auto-Adjust Function

In order to ensure optimal display image quality, this product utilizes the Auto-Adjust function. When the Auto-Adjust function is operating, it may take a short time before the screen displays properly. The settings initiated by Auto-Adjust are saved in the display.

**Hint:** If the Auto-Adjust function is operating, the horizontal and vertical positions as well as the phase and pitch of the display are adjusted automatically when the display mode is received. The Auto-Adjust function becomes operational when the horizontal frequency is in the 30-56.5KHz and the vertical frequency is in the 45-75Hz range.(When resolution is 1024 × 768 dot (XGA), vertical frequency is in the 45-70Hz range).

**Important:**When the Auto-Adjust function is operating, only the power switch is operational.

## The DTI-520UB Power Saving Function

This product is in compliance with VESA power-saving guidelines. When connected to a Display Power Management (DPMS)-compatible computer and graphics board, the power savings indicated below are automatically realized during times of non-operation.

Computer Activity	Horizontal Synchronizing Signal	Vertical Synchronizing Signal	Picture Signal	Power Consumption	Power Lamp
Turned On	Yes	Yes	Yes	23W or less	Blue
Stand-by Mode	No	Yes	No	Less than 2W	Orange/Blue*
Suspend Mode	Yes	No	No	Less than 2W	Orange/Blue*
Off Mode	No	No	No	Less than 1W	Orange

**Caution:**\*Depending on the specifications and settings of your computer and video card, when in standby and suspend modes, the power lamp may only light up orange.

## Protrusion of the Picture from the LCD Panel and the Blurring of Characters...

**Caution:** This setting is effective when the product and computer are connected by a RGB cable.

Depending on the type of computer and graphics board, the Auto-Adjust function is sometimes not able to operate at full power, resulting in the picture blurring and protruding from the LCD panel. If this happens, adjust the pitch and phase. At 1024 x 768-bit, the resolution is optimally adjusted.

### Procedure:

- 1 Open the Tablet Control Panel (see page 21) and select the Calibrate tab.
- 2 Click on the Calibrate... button. An adjustment pattern for pitch and phase will appear.
- 3 Using the OSD controls, open the OSD Menu and the Pitch icon. → P.16,18
- 4 Adjust the pitch level so the pattern of fine vertical stripes display evenly.
- 5 In the OSD Menu, select the Phase icon.
- 6 Adjust the phase level so the adjustment pattern shows clearly. → P.16,18
- 7 After completing these adjustments, press the ENTER and MENU buttons to exit the OSD Menu.
- 8 Click on the CANCEL button or press the ENTER and MENU buttons to exit the OSD Menu.

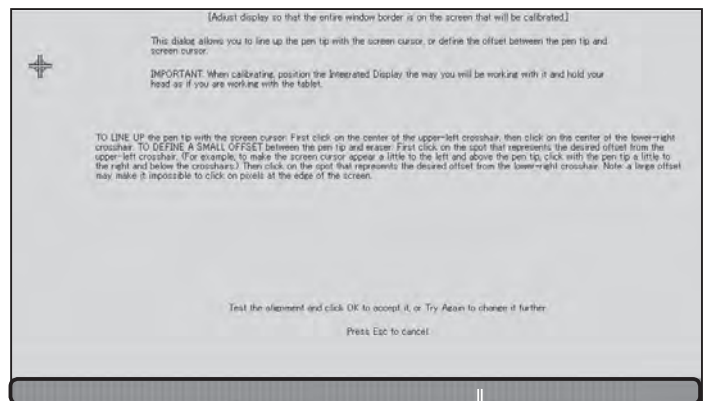
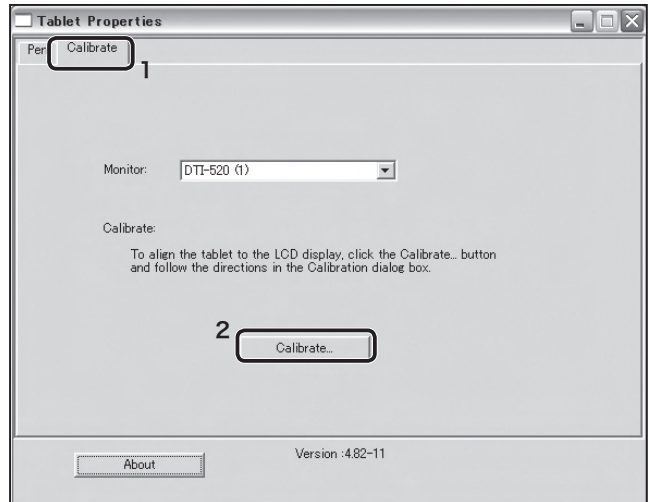

Adjustment pattern for pitch and phase

**Hint:** For Windows 2000, the pitch and phase may be calibrated after the Exit Windows screen is displayed. If the frequency needs to be calibrated, light and dark vertical stripes will appear in the dark areas of the screen. If the tracking needs to be calibrated, light and shade will appear horizontally in the dark areas of the screen (for 1024 x 768-bit resolution).

This method is recommended in situations where the tablet driver has not been installed.

## Button Functions

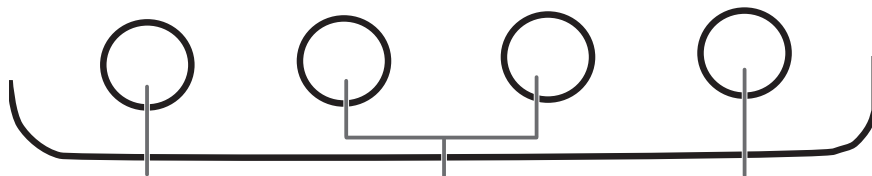

### Menu button :

Opens or closes the OSD Menu.

### - buttons, + buttons :

You can select an option that can be activated. After activating a selected option, press the + button to increase a selected item value, and press the - button to decrease it.

### ENTER Button

Activates or deactivates the selected OSD menu option. Also switches the image input from the RGB - RGB cable and the image input from the composite video cable.

## Adjusting the Brightness and Contrast of the Display

Adjusting picture quality and setting up the display are accomplished by using on-screen buttons to establish and change adjustment items and values. Click on the Menu button and the menu screen appears. Select the items to be adjusted and their desired settings.

### How to Use the OSD Menu

Example: Adjusting the brightness

**1** Click on the Menu button to display the Main Menu Settings screen.

**2** Click on the + button and the - button and select the items to be adjusted. When the option you want to adjust is highlighted, press the ENTER button.

**3** Use the + and - buttons to adjust numerical values and other items.

**4** After making your change, press the ENTER button to save.



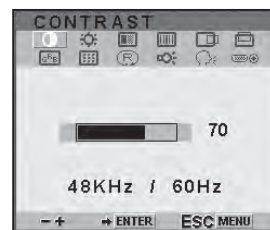

**5** To exit, press the Menu button.

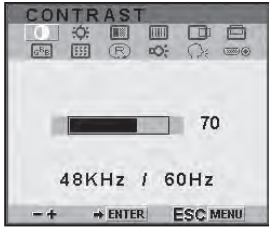

# Types of OSD Menu

Some menu screen displays may vary depending on whether a RGB cable or a video cable is connected. The following screens explained in Common Screens below are the same ones regardless of the connection method.

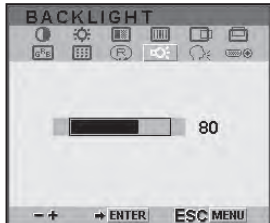
## Common Screens

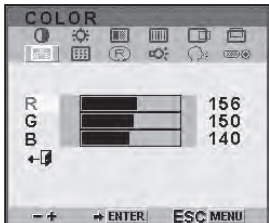
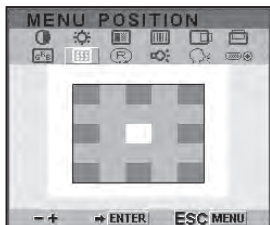
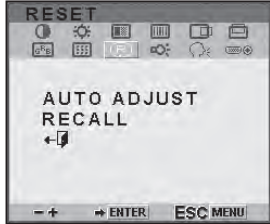

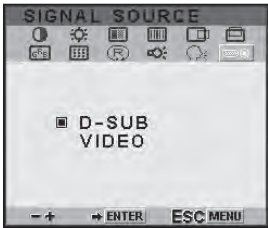

<p><b>Contrast</b></p> <p>Select to increase or decrease image contrast.</p> 	<p><b>Language</b></p> <p>Select to choose a language option for the OSD: English, Deutsch, Francais, Espanol, Italiano, or Japanese.</p> 
<p><b>Brightness</b></p> <p>Select to increase or decrease image brightness.</p> 	<p><b>Backlight</b></p> <p>Selects to increase or decrease the backlight brightness level.</p> 
<p><b>Color</b></p> <p>Provides settings for 9300°, 6500°, and 5000°Kelvin. Also provides a User option that enables you to adjust red, blue and green independently. Selecting DIRECT displays the received signal as it is without any adjustment. Choose a setting to work with and press Enter to activate your selection. You can change the user setting by selecting the icon '↵'. In the User Adjustment window, change red, blue and green to calibrate color. To exit, select the icon '↵'.</p>  	<p><b>Menu Position</b></p> <p>Select to move the OSD menu around the display.</p>  <p><b>Reset</b></p> <p>Provides two options: Use AUTO ADJUST to reset only the image parameters. Use RECALL to reset all screen options to the factory default. Selecting the exit '↵' icon exits the RESEST window without resetting anything.</p> 

**Signal Source**



Select D-SUB and the image input from the RGB – RGB cable displays.  
 Select VIDEO and the image input from the composite video cable displays.



● **Screens that Display with a RGB Cable Connection**

<p><b>Horizontal Center(VGA only)</b></p> <p>Select to move the screen image left or right.        To automatically adjust, use the Reset option.</p> 	<p><b>Phase (VGA only)</b></p> <p>Select to reduce or eliminate horizontal distortion lines.        To automatically adjust, use the Reset option.</p> 
<p><b>Vertical Center (VGA only)</b></p> <p>Select to move the screen image up or down.        To automatically adjust, use the Reset option.</p> 	<p><b>Pitch (VGA only)</b></p> <p>Select to reduce or eliminate vertical distortion lines.        To automatically adjust, use the Reset option.</p> 

● **Screens that Display with a Video Cable Connection**

<p><b>Saturation</b></p> <p>Adjust saturation of a image.</p> 	<p><b>Sharpness</b></p> <p>Adjust sharpness of a image.</p> 
<p><b>Hue</b></p> <p>Adjust hue of a image.</p> 	

# Pen

## The Parts of the Pen and Their Functions

### Eraser

It works like the eraser on a pencil.

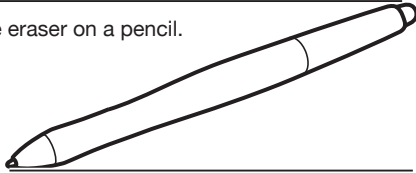

### Pen Tip

- You can change the position of the screen pointer by moving the tip of the pen.
- By varying the amount of pressure applied, the boldness of lines and the size of points can be adjusted.
- If the pen nib shows signs of wear, it can be replaced. See page 24.

## Gripping the Pen

You can hold it just like a pen.

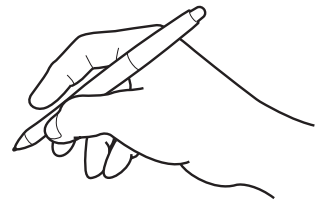

## Basic Operations of the Pen

### Moving the Pointer

By raising the pen a little above the screen and moving it, you can move the position of the screen pointer.

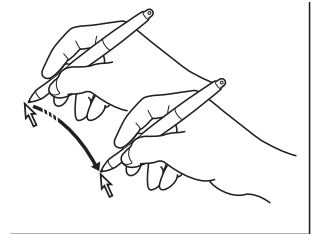

### Clicking and Double-clicking

#### Clicking

Tap on the screen lightly once with the tip of the pen to click.

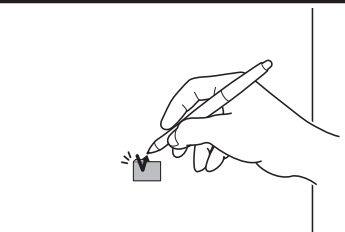

### Double-clicking

Tap in the same place twice quickly with the tip of the pen to double-click.

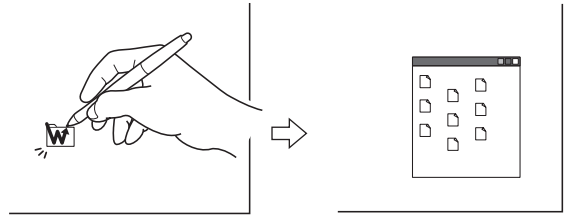

## Dragging

Select an icon or folder and then, while keeping the pen tip pushed down, move the pen to move the object.

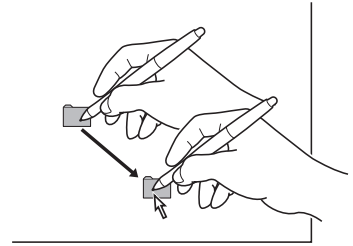

## Using the Eraser

By setting the eraser function and then tracing over the display, pictures and handwritten characters disappear as if erased by a standard eraser.

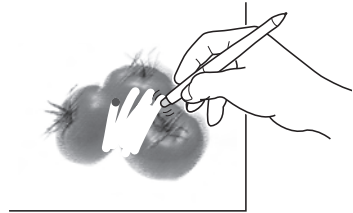

## How to use the Tablet Button

The tablet buttons are connecte the efficiency of your work.

Note: The tablet buttons can be used in Windows-based PCs. To use the tablet buttons, you have to install the button driver to your PC.( → P12)

## Component Functions

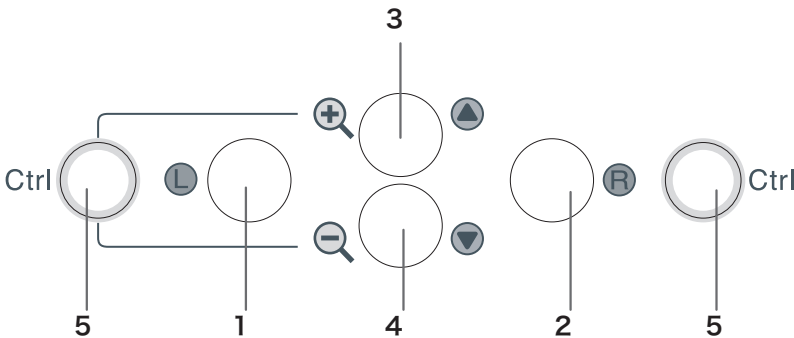

No	Function	Description
1	The left mouse button	It works like the left mouse button.
2	The right mouse button	It works like the right mouse button.
3	Scroll button (Top)	It scrolls the display of a monitor to upper side.
4	Scroll button (Bottom)	It scrolls the display of a monitor to lower side.
5	Ctrl button	A role of a ctrl button

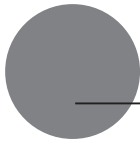

# Using the Control Panel

Change the settings for the pen and adjust the pointer and pen tip positions with the control panel.

\*When connecting and using multiple tablets, see page 23.

## Displaying the Control Panel

### Opening the Control Panel in Windows

Click on the Windows Start button, go to All Programs (P) or Programs (P), open Wacom Tablet and select Wacom Tablet Properties.

### Opening the Control Panel in Macintosh

Open System Settings and then Wacom Tablet.

## Control Panel Basics

You select the pen tab.

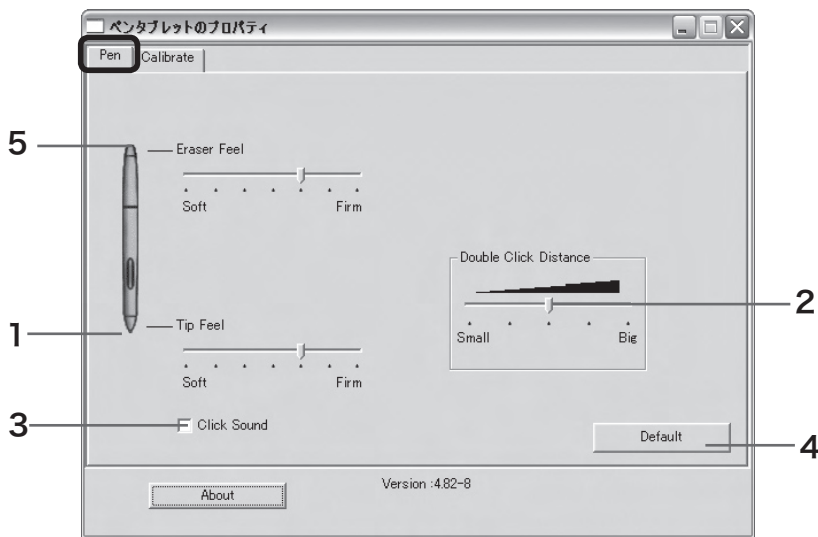

NO	Setting Item	Description
1	Tip Feel	Customizes the amount of pressure needed to click or draw with the pen.
2	Double Click Distace	Adjusts the size of the double-click area. See page 20.
3	Click Sound	When checked, an audible “click” sound will be heard whenever a pen click occurs and your computer speakers are turned on.
4	Default	Returns the PEN tab settings to their factory defaults.
5	Eraser	It works like a eraser.

# Synchronizing the Positions of the Pen Tip and Pointer

Make the necessary adjustments so that when the pen nib is brought near the LCD screen, the pointer displays properly in the area where the pen nib is placed (parallactic adjusting).

\* When using an analog RGB input type of LCD pen tablet, please refer to “Protrusion of the Screen from the LCD Panel and the Blurring of Characters” on page 15 and make any necessary adjustments to the screen.

\* When using multiple tablets, see page 23.

**1** Click on Calibrate... and the screen used for making adjustments will appear.

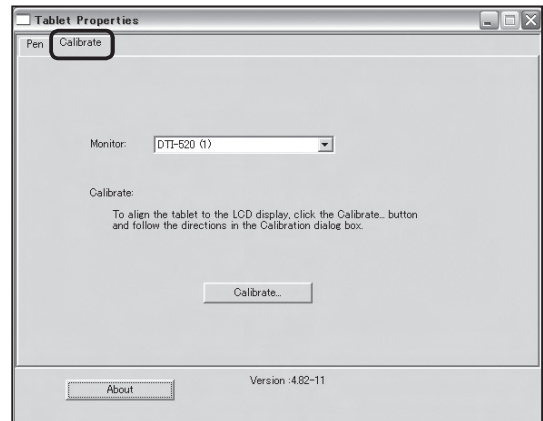

**2** Click in the middle of the cross mark in the upper left-hand corner of the screen while sitting in your normal seating position with the pen nib and the cross mark will move to the bottom right-hand side of the screen.

**3** Click again in the middle of the cross mark that is now in the bottom right-hand corner of the screen while sitting in your normal seating position and the cross mark will disappear. The process of synchronizing positions is now complete.

Click on the OK button in the lower part of the screen to close the screen.





## Setup Procedures for when Multiple Interactive Pen Tablets are Connected

---

When multiple interactive pen tablets are connected and are to be used, it is necessary to set up the pen and calibrate for each interactive pen tablet individually. Please follow the procedures below to carry this out.

- 1** Bring the pen tip near the display of the tablet for which the setup is to take place. Verify that the pointer moves in conjunction with the pen tip.
- 2** Open the control panel. (Please refer to the screen picture accompanying Step 1 of the procedure described in “Protrusion of the Picture from the LCD Panel and the Blurring of Characters...” on page 15.)
- 3** Open the Calibrate tab and verify that the correct monitor name is displayed in the Monitor field.

### ● If Another Monitor Name is Displayed in the Monitor Field...

The control panel of a different interactive pen tablet is being displayed. Press the ESC key on the keyboard to delete the control panel and, beginning with Step 1, repeat the above procedure to display the correct control panel.

\*If the monitor name is changed without displaying the control panel, the tablet will not be able to be set up.

### **[Important]**

**When more than one interactive pen tablet is connected, the control panel of the last tablet to recognize the pen tip is displayed. Even after identifying the pointer, if you use the pen on another tablet to open its control panel, the pen tip is recognized and the control panel of this tablet opens. Please refer to the following example.**

**Example >** Setting up Tablet A when Tablet A and Tablet B are connected.

1. The pointer is identified by Tablet A.
2. The control panel of Tablet A is displayed. → OK  
The pen is used on Tablet B to display the control panel → NOT OK (This carries out the setup of Tablet B).  
The computer mouse is used on Tablet B to display the control panel → OK

- 4** Refer to “Protrusion of the Picture from the LCD Panel and the Blurring of Characters...” on page 15 and carry out calibrations.

To set up the pen, open the PEN tab and carry out the setup.

- 5** Repeat Steps 1 – 4 to set up another tablet.

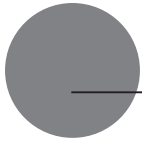

# Supplementary Information

## Removing Stains

If the product casing or pen becomes soiled, wipe off with a clean, soft cloth.

If this fails to remove the stains, soak a clean, soft cloth with a water-diluted detergent mixture, wring thoroughly and wipe off.

If the protective covering for the LCD display becomes soiled, wipe with a dry, soft cloth. If the stain is difficult to remove, try moistening the cloth slightly.

**Caution:** Do not use detergents for cleaning. The use of detergents may adversely affect the performance of the pen. Also, do not use organic solvents, as they may cause surface discolouration.



## Replacing the Pen Nib

When the pen nib becomes worn down so that it is 1mm or less in length, replace it as shown in the illustration below. If the pen nib becomes worn down and angular in shape, it can easily damage the surface of the protective covering of the LCD display.

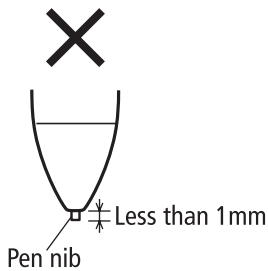

### Remove the pen nib

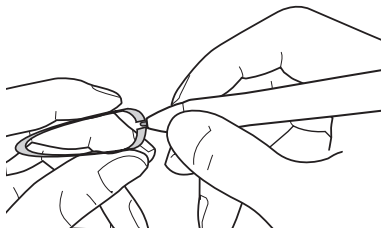

Using a pair of tweezers or a similar tool, pull the nib out of the pen.

### Insert a new nib

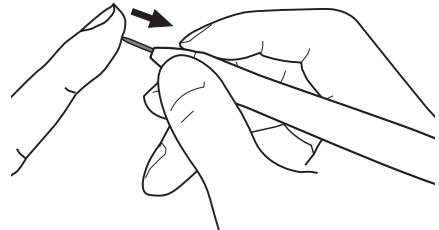

Insert the new nib, firmly pushing it in until it stops.



**Caution:** Please prevent children from placing the grip pen or pen nib in their mouths. There is the danger that the nib may be pulled out and swallowed. If the grip pen is placed in the mouth, it may be damaged.



# Troubleshooting

## Display Troubleshooting

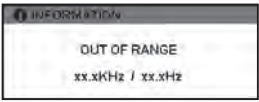
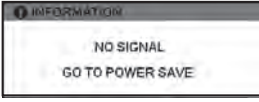
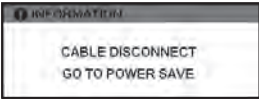
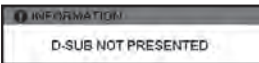
### If One of These Messages Should Appear...

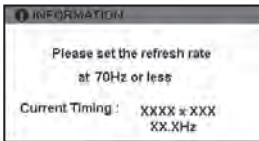
Message	What to Do	Reference
	<p>Prior to connecting the product, if you have a monitor that you have been using, connect it and then adjust the horizontal frequency to 30–80 kHz and the vertical frequency to 50 –75 Hz. Connect the product.</p>	-
	<ul style="list-style-type: none"> <li>- Verify that the video signal cable* is connected.</li> <li>- Verify that the video signal cable connector pins are not bent or broken.</li> <li>• When the computer goes in to power saving mode, move the mouse or press any keyboard key.</li> <li>• Verify that the computer graphics board is correctly installed.</li> </ul>	<p>P.11</p> <p>-</p> <p>-</p> <p>-</p>
	<ul style="list-style-type: none"> <li>• Verify that the video signal cable is connected.</li> <li>• Verify that the video signal cable connector pins are not bent or broken.</li> <li>• If you are using a cable other than the video signal cable that was included with the product, this message may appear prior to the computer going into power-saving mode. The product is not out of order. Use the cable that was included to connect the product.</li> </ul>	<p>P.11</p> <p>-</p> <p>P.9</p>
	<p>The RGB – RGB cable is not connected.</p>	P.11
	<p>The composite video cable is not connected.</p>	P.11
	<p>Set the refresh rate so that it is 70Hz or less. The refresh rate may be adjusted at the Screen Profile dialog box for your computer.</p>	-

**Caution:**\* Video signal cable indicates both USB cables (see page 9).

### If One of These Conditions Should Appear...

Condition	What to Do	Reference
<p>The power lamp lights up orange or orange and blue.</p>	<ul style="list-style-type: none"> <li>• Verify that the video signal cable is connected.</li> <li>• Verify that the video signal cable connector pins are not bent or broken.</li> <li>• When the computer goes in to power saving mode, move the mouse or press any keyboard key.</li> <li>• Verify that the computer graphics board is correctly installed.</li> </ul>	<p>P.11</p> <p>-</p> <p>-</p> <p>-</p>
<p>The power lamp doesn't light up and the screen doesn't display.</p>	<ul style="list-style-type: none"> <li>• Verify that the power cable is connected and turn the power switch on.</li> </ul>	P.10-11
<p>The screen doesn't display even when the power switch is turned on.</p>		-

Condition	What to Do	Reference
The picture is distorted	<ul style="list-style-type: none"> <li>• Adjust the pitch and phase.</li> <li>• Verify that your computer display adapter is compatible with the product.</li> <li>• Verify that the graphics mode and frequency for the input signal are compatible with the product.</li> <li>• Adjust the computer's refresh rate (vertical frequency) for optimal display.</li> </ul>	<b>P.16-18</b>
The picture appears wavy		-
The picture flickers		<b>P.28</b> <b>P.28</b>
The picture is not clear	<ul style="list-style-type: none"> <li>• Adjust the contrast and brightness.</li> <li>• Adjust the pitch and phase.</li> <li>• Set your computer's resolution to XGA (1024 x 768).</li> </ul>	<b>P.16-17</b> <b>P.16-18</b>
The picture appears doubled or in triplicate	<ul style="list-style-type: none"> <li>• Do not add an extension to the video signal cable and refrain from using the input selector.</li> <li>• Connect the video signal cable firmly to the connector.</li> </ul>	- -
The picture is out of position	<ul style="list-style-type: none"> <li>• Adjust the pitch and phase.</li> <li>• Adjust the horizontal and vertical positioning. Depending on the input signal and video card, the picture may not entirely fill the screen.</li> </ul>	<b>P.16-18</b>
The picture size is incorrect		<b>P.16-18</b>
The picture is dark.	<ul style="list-style-type: none"> <li>• Adjust the brightness.</li> </ul>	<b>P.16-18</b>
Waves and vertical stripes appear in the picture.	<ul style="list-style-type: none"> <li>• Adjust the pitch and phase.</li> </ul>	<b>P.16-18</b>
The picture colour is uneven.	<ul style="list-style-type: none"> <li>• Adjust the colour temperature.</li> </ul>	<b>P.16-17</b>
The colour white does not display as white.		

### The Pen and Side Switch do not Operate Correctly (For Both Windows and Macintosh)

Condition	What to Do	Reference
The pen nib produces a click even when only very lightly coming in contact with the screen.	Use the control panel to set the pen nib sensitivity to Firm setting.	<b>P.21</b>
The pen does not produce a click unless excessive pressure is used.	Use the control panel to set the pen nib sensitivity to Soft setting.	<b>P.21</b>
The pen nib produces a click prior to coming into contact with the screen.	Use the control panel to set the pen nib sensitivity to Firm setting. When the status lamp turns blue in response to the pen nib being moved to close proximity to the screen, either the pen or the tablet is probably defective.	<b>P.21</b>
The pen nib do not work.	Please verify that the status lamp turns blue when the pen nib and side switch are pushed. If the lamp doesn't change colours, this probably indicates that either the pen or the tablet is probably defective.	<b>P.6</b>
The pen cannot be double-clicked using the pen nib.	If possible, quickly click in the same area. In the control panel, set the double-clicking interval to a longer setting and set the pen nib sensitivity to a lighter setting. Verify that the double-click speed setting is not too fast in the regular mouse control panel.	- <b>P.21</b> <b>P.21</b>
The pressure function cannot be used.	Please refer to your software application and the store where you bought the application to verify whether it is pressure function-enabled. Some applications have special settings that must be established before the pressure function becomes operational. The tablet driver probably is not installed properly. Try re-installing it.	- <b>P.12-13</b>

## General Troubleshooting

Condition	What to Do	Reference
When a replacement computer is purchased or new software is used, the tablet cannot be used.	Installing the newest version of tablet driver may resolve this problem. The newest tablet driver can be downloaded from the Wacom homepage	-
The tablet, which is connected to a USB hub, doesn't respond.	Some USB hubs cannot recognize tablets. Connect the tablet directly to the computer's USB port.	-

## Troubleshooting for Windows

Condition	What to Do	Reference
Even when connected to the USB port, the pen is inoperable.	<ul style="list-style-type: none"> <li>• Check the connection of the USB connector. If using a USB hub connection, try connecting directly to the computer's USB port.</li> <li>• When the product model type appears in the Unknown Device list, select it and click the Delete button, canceling all settings for it. Next, click the Renew button and, following the directions in the New Hardware dialog box, re-install the tablet driver.</li> <li>• If use of the USB port is advantageous, open the Control Panel folder and then the System folder. Then open, in order, the Hardware and Device Manager folders. Next, check and make sure that USB (Universal Serial Bus) Controller appears in the list that is displayed. If it isn't present, it will be necessary to adjust your computer. Please consult your computer maker regarding this.</li> </ul>	P.11
		-
		-
When Windows is in DOS full screen mode, moving the pointer with the pen becomes impossible.	When using a DOS mouse, the pen is inoperable. You must use another mouse.	-
If the mouse is set for left-handed use in the regular mouse control panel, the ability to click with the pen nib is lost.	Restart Windows.	-

## Troubleshooting for Macintosh

Condition	What to Do	Reference
Even when connected to the USB port, the pen is inoperable.	- Check the connection of the USB connector. Connect directly to the computer's USB port.	P.11
	- If equipped with a USB card, the system software has probably not been installed properly.	-
	- If you have any other high-speed, high-power USB peripherals, connect these and check and see whether they operate properly or not. If these other units operate properly, this would seem to indicate that the tablet is defective.	-
The product always reverts to mouse mode and the pressure function cannot be used.	The tablet driver may not be properly installed. Try reinstalling it.	P.12-13

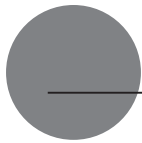

# Specification

---

## General Specifications

---

Physical dimensions(W D H):	344 × 300 × 49 mm (excluding stand)
Weight:	4.4kg (including stand)
Main unit input voltage:	DC12V
Power consumption:	23 W or less (DC12 V)
Usage temperature and humidity ranges:	5–35 degrees C, 20–80%RH (conditions where condensation does not form)
Storage temperature and humidity ranges:	-10–60 degrees C, 20–90%RH (conditions where condensation does not form) (at 60 degrees C maximum storage humidity is 38%; at 90% humidity, maximum storage temperature is 42 degrees)

---

## LCD Display Specifications

---

Display:	a-Si TFT Active Matrix LCD
Screen size:	15 inches
Resolution (75Hz Max.):	1024 × 768 dot (XGA), 800 × 600 dot (SVGA), 640 × 480 dot (VGA)
Pixel pitch:	0.297(W) × 0.297 (H) mm
Display dimensions:	304.1 × 228.1mm
Color depth:	253 level; 16,190,000 colors
Signal inputs:	Analog RGB input 0.7 Vp-p, 75Ω, straight polarity Synchronous inputs: TTL level, 2.2 kΩ, polarity freedom (horizontal / vertical separation or composite synchronous input) Digital inputs: DVI 1.0 Synchronous frequency: horizontal: 30 – 56.5 kHz; vertical 45 – 75 Hz.(When resolution is 1024 × 768 dot (XGA), vertical frequency is in the 45-70Hz range) Scanning method: all non-interlace
Plug and Play:	DDC2B

---

\* On rare occasions, light and dark dots may appear on a small part of the display screen. This condition does not indicate product failure.

\* Afterimages may remain on the screen after still images have been displayed for a long period of time, but these will disappear after a short period of time.

## Tablet Specifications

---

Reading method:	Electromagnetic induction method
Maximum reading range:	304.1 × 228.1mm
Reading resolution:	Maximum 20 lpmm (0.05 mm)
Reading accuracy:	+/- 0.5 mm; four corners( 20mm wide, 80mm long from esch corner of four "L" shaped area) to be +/- 2.0 mm.
Maximum reading height:	5mm
Data transfer rate:	Maximum 100 points per second
Pressure level:	512 levels
Interface:	USB, RS-232C

---

## Grip Pen Specifications )

---

Pressure functions:	Pen nib switch
Pen nib switch type /retraction motion:	Non-retractable/0.2 mm or less
Load when pen nib is switched on:	30 g or less
Physical dimensions and weight:	12.5 × 147.5 mm, 10 g

---

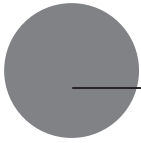

# Warranty

(WORLDWIDE, EXCEPT FOR EUROPE, AFRICA AND MIDDLE EAST)

## Limited warranty

Wacom warrants the product, to the original consumer purchaser, except for the Software and consumable items such as the pen nibs, to be free from defects in materials and workmanship under normal use and service for a period of two (2) years, from the date of original retail purchase, as evidenced by a copy of the receipt and registration with Wacom within 30 days of purchase.

The Software is licensed “as is.” Wacom makes no warranty with respect to its quality or performance. Wacom cannot guarantee you uninterrupted service or the correction of any errors.

Upon discovery of a defect in the product, except in the Software, within the Warranty Period, you should contact Wacom Technical Support via telephone, email, or fax to obtain an RMA (Return Merchandise Authorization) number and instructions for shipping the product to a service location designated by Wacom. You should send the product, shipping charges prepaid, to the designated service location, accompanied by the return authorization number, your name, address and telephone number, proof of purchase date, and a description of the defect. Wacom will pay for return shipping by United Parcel Service or by an equivalent service as chosen by Wacom.

Wacom’s sole obligation and entire liability under this warranty shall be, at Wacom’s option, either the repair or replacement of the defective product or parts thereof of which Wacom is notified during the Warranty Period; provided, however, that you are responsible for (i) the cost of transportation of the product to the designated service location and (ii) any loss or damage to the product resulting from such transportation.

Wacom shall have no responsibility to repair or replace the product if the failure of the product has resulted from accident, abuse, misuse, negligence, or unauthorized modification or repair, or if it has been handled or stored other than in accordance with Wacom’s storage instructions.

Any descriptions, drawings, specifications, samples, models, bulletins, or similar material, used in connection with the sale of the product, shall not be construed as an express warranty that the product will conform or comply with your requirements.

EXCEPT FOR THE LIMITED WARRANTY DESCRIBED ABOVE, THERE ARE NO OTHER WARRANTIES MADE BY WACOM ON THIS PRODUCT. NO ORAL OR WRITTEN INFORMATION OR ADVICE GIVEN BY WACOM, ITS DEALERS, DISTRIBUTORS, AGENTS, OR EMPLOYEES SHALL CREATE A WARRANTY OR IN ANY WAY INCREASE THE SCOPE OF THIS WARRANTY, AND YOU MAY NOT RELY ON ANY SUCH INFORMATION OR ADVICE. THIS WARRANTY GIVES YOU SPECIFIC LEGAL RIGHTS, AND YOU MAY ALSO HAVE OTHER RIGHTS WHICH VARY FROM STATE TO STATE. WACOM LIMITS THE DURATION OF ANY LEGALLY IMPLIED WARRANTIES INCLUDING IMPLIED WARRANTIES OF MERCHANTABILITY OR FITNESS FOR A PARTICULAR PURPOSE, TO THE DURATION OF WACOM’S EXPRESS WARRANTY. SOME STATES DO NOT ALLOW LIMITATIONS ON HOW LONG AN IMPLIED WARRANTY LASTS, SO THE ABOVE LIMITATION MAY NOT APPLY TO YOU.

NEITHER WACOM NOR ANYONE ELSE WHO HAS BEEN INVOLVED IN THE CREATION, PRODUCTION, OR DELIVERY OF THIS PRODUCT SHALL BE LIABLE FOR ANY DIRECT, CONSEQUENTIAL, OR INCIDENTAL DAMAGES (INCLUDING DAMAGES FOR LOSS OF BUSINESS PROFITS, BUSINESS INTERRUPTION, LOSS OF BUSINESS INFORMATION AND THE LIKE) ARISING OUT OF THE USE OF OR INABILITY TO USE SUCH PRODUCT, EVEN IF WACOM HAS BEEN ADVISED OF THE POSSIBILITY OF SUCH DAMAGES. SOME STATES DO NOT ALLOW THE EXCLUSION OR LIMITATION OF INCIDENTAL OR CONSEQUENTIAL DAMAGES, SO THE ABOVE LIMITATION OR EXCLUSION MAY NOT APPLY TO YOU.

In the event that any of the above limitations are held unenforceable, Wacom's liability for any damages to you or any party shall not exceed the purchase price you paid, regardless of the form of any claim.

This Limited Warranty is governed by the laws of the United States of America and the state of Washington. This Limited Warranty is valid for and only applies to products purchased and used inside the United States (and its territories or possessions) and Canada.

## Warranty service outside of the U.S.A. and Canada

For products purchased or used outside of the United States and Canada, the warranty period is one (1) year from the date of original retail purchase. Upon discovery of a defect in the product, except in the Software, within the Warranty Period you should contact your local dealer or distributor. If an authorized Wacom repair center is not available in your local country you will be responsible for all transportation costs including duties and taxes to and from the Wacom repair center. In all other respects the terms of the warranty as set forth above apply to such sales.

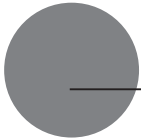

## Obtaining Technical Support

If you experience a problem with this product that cannot be solved by referring to this guide or the manual included with your driver CD, please refer to our online FAQ or contact our support staff.

Please visit [www.wacom-asia.com/support](http://www.wacom-asia.com/support) or contact us using the form at [www.wacomasia.com/inquiry](http://www.wacomasia.com/inquiry) if you have questions that need to be answered by phone or e-mail.

Phone support hours: 9am - 6pm on weekdays. (Note: Hours may vary by region. Phone numbers for Australia, New Zealand, Singapore, Malaysia, Thailand and Taiwan are available online.)

-----  
Support for Hong Kong residents is available from Wacom Hong Kong Ltd.

URL: [www.wacom.com.hk](http://www.wacom.com.hk)

Tel: (852) 2573-9322, Fax: (852) 2573-9500

Email: [sales@wacom.com.hk](mailto:sales@wacom.com.hk)  
-----

Regarding Limited Warranty in the Asia Pacific region (excluding China and Hong Kong) Wacom Co., Ltd. warrants the product, to the original consumer purchaser, including the main unit and accessories such as the AC adapter and cables, to be free from defects in materials and workmanship under normal use and service for a period of one (1) year, from the date of original retail purchase, as evidenced by a copy of the receipt (proof of purchase) or if issued, the warranty card from your local reseller or distributor. Wacom's Limited Warranty Policy for Asia Pacific can be found on the Asia Pacific website at: [www.wacom-asia.com/technical/warranty](http://www.wacom-asia.com/technical/warranty)  
Premium Extended Warranty Service is available in Asia Pacific  
[www.wacom-asia.com/technical/warranty/premiumwarranty.html](http://www.wacom-asia.com/technical/warranty/premiumwarranty.html)